

MODEL:

SRWO16US

SmartRack® 16U Wall-Mount 2-Post Open Frame Rack



16 Rack Units



150 lb. Load Rating



Standard 19 in.
Rack Width

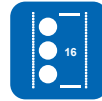

12-24 Threaded
Hole Mounting



Sturdy Steel
Construction

- A** Wall-Mount Brackets
- B** Vertical Mounting Rails (2)
- C** Swinging Door with Hinge
- D** Threaded (12-24) Mounting Holes

Also includes hex bolts (16) and owner's manual.

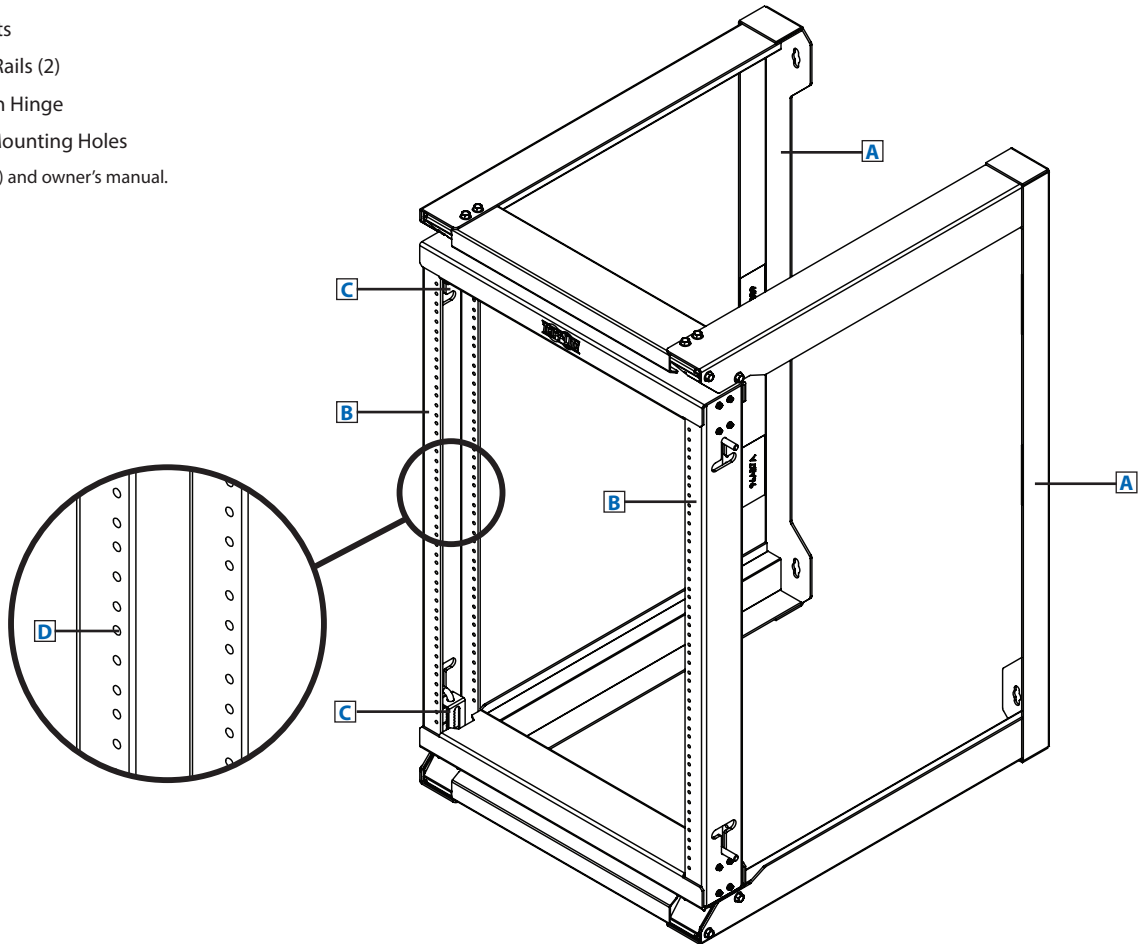

- Provides convenient storage for rack-mount equipment that should be off the floor and out of the way
- 2-post open-frame design is ideal for IT environments that do not require a lockable enclosure cabinet
- Ships disassembled for easy transport and assembly
- Threaded (#12-24) mounting holes enable fast equipment mounting
- Ideal for cost-conscious 19-inch rack-mount applications

SEE NEXT PAGE FOR DETAILED UNIT MEASUREMENTS

Specifications

Model	SRWO16US
Rack Spaces:	16U
Equipment Mounting Depth:	23.5 in. (59.7 cm)
Load Rating*:	150 lb. (68 kg)
Unit Dimensions (H x W x D):	36.6 x 22.3 x 25.2 in. (93 x 56.6 x 64 cm)
Unit Weight:	71.7 lb. (32.5 kg)
Certifications:	IEC 60297-3-100, RoHS, TIA/EIA-310-D (Accommodates all standard 19-inch rack-mount equipment regardless of vendor.)

* Load rating includes the combined weight of unit and all installed equipment. Unit must be mounted to a stable surface with user-supplied anchors capable of bearing the full load. We have a policy of continuous improvement. Specifications are subject to change without notice. Photos and illustrations may differ slightly from actual products.



TRIPP-LITE
by **EATON**

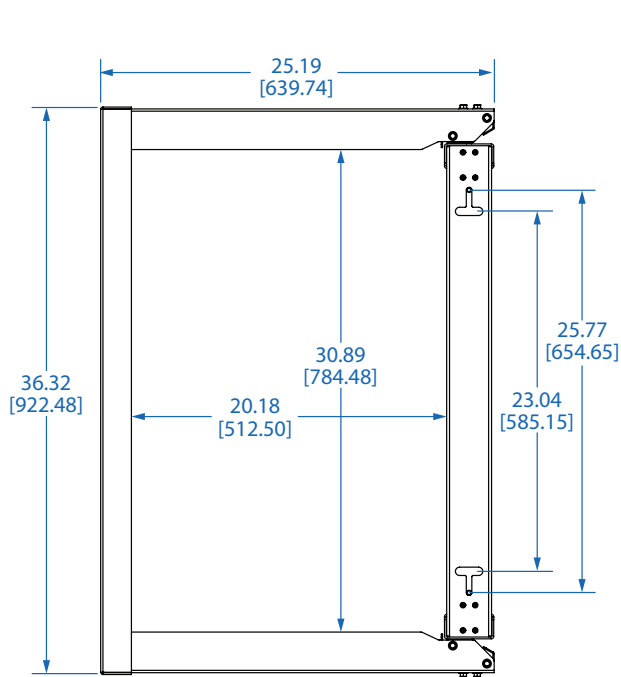

SIDE VIEW

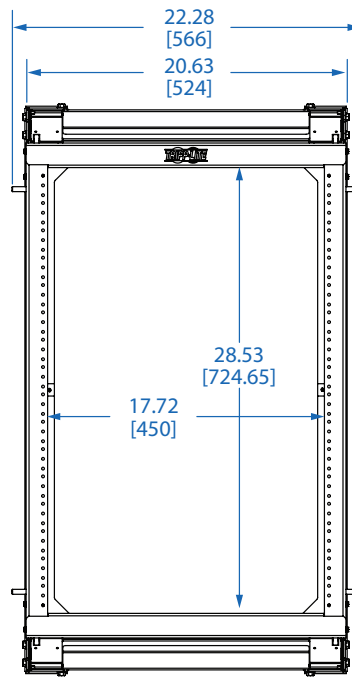

FRONT VIEW

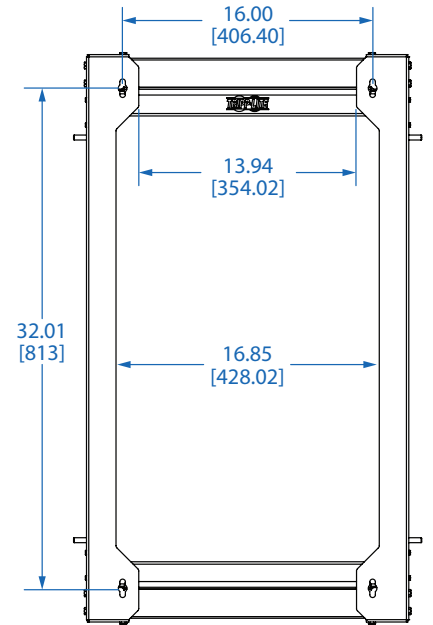

BACK VIEW

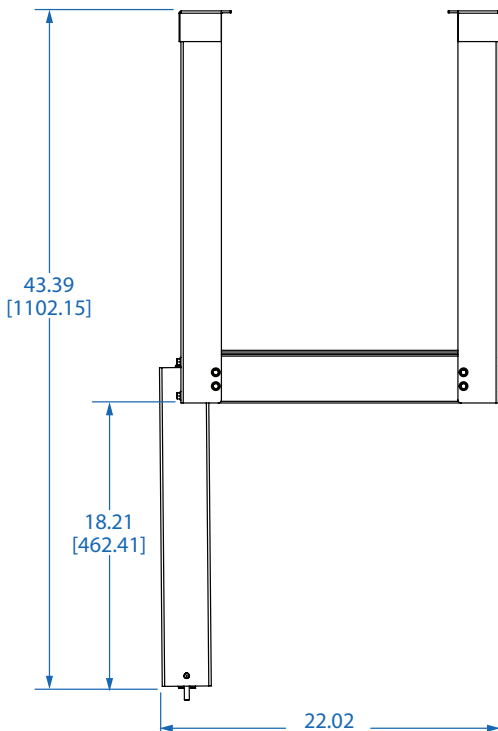

OPEN TOP VIEW

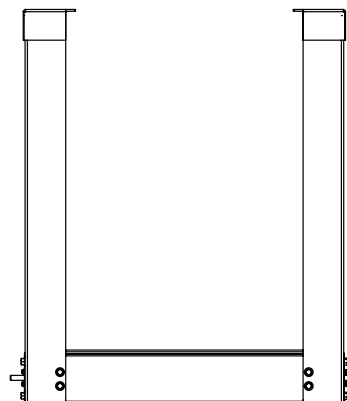

TOP VIEW

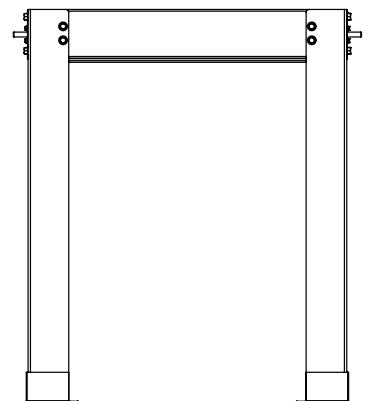

BOTTOM VIEW

Dimensions: inches [mm]

We have a policy of continuous improvement. Specifications are subject to change without notice. Photos and illustrations may differ slightly from actual products.

Model:
SRWO16US

TRIPP-LITE
by **EATON**

1111 W. 35th Street
Chicago, IL 60609 USA
773.869.1234
triplite.com

About Tripp Lite by Eaton

Tripp Lite joined the Eaton family in March 2021. Eaton has long been a premier name in backup power and power management. The acquisition of Tripp Lite transforms Eaton's distributed IT infrastructure and connectivity equipment capabilities. Combining our product strengths and expert personnel allows us to offer comprehensive and innovative solutions for critical power and digital infrastructure applications, backed by quality, service and support you can trust. Learn more at triplite.com/byEaton.