

MODEL:

SRX12UBFFD

SmartRack® 12U Industrial Floor Rack Enclosure



12 Rack Units



1000 lb.
Load Rating



Accommodates
Standard
19-Inch
Equipment



Dust, Drip and
Splash Protection
(IP54)



Heavy-Duty
Casters



Louvered Door
for Drip-Resistant
Ventilation



4 Fans for
Superior Airflow



Replaceable
Dust Filter



Square Hole
Mounting

- A** Louvered Front Door (Lockable)
- B** Dust Filter
- C** Rear Door (Lockable)
- D** High-Performance Intake Fans (4)
- E** Side Panels (Lockable/Removable)
- F** Adjustable Mounting Rails with Easy-View Depth Index
- G** Dust- and Drip-Resistant Cable Ports
- H** Heavy-Duty Casters (4) and Levelers (4)
- I** Keys (For Doors and Side Panels)

Also Includes: Owner's Manual and rackmount equipment mounting hardware (36 cage nuts, 36 mounting screws, 36 nylon cup washers)

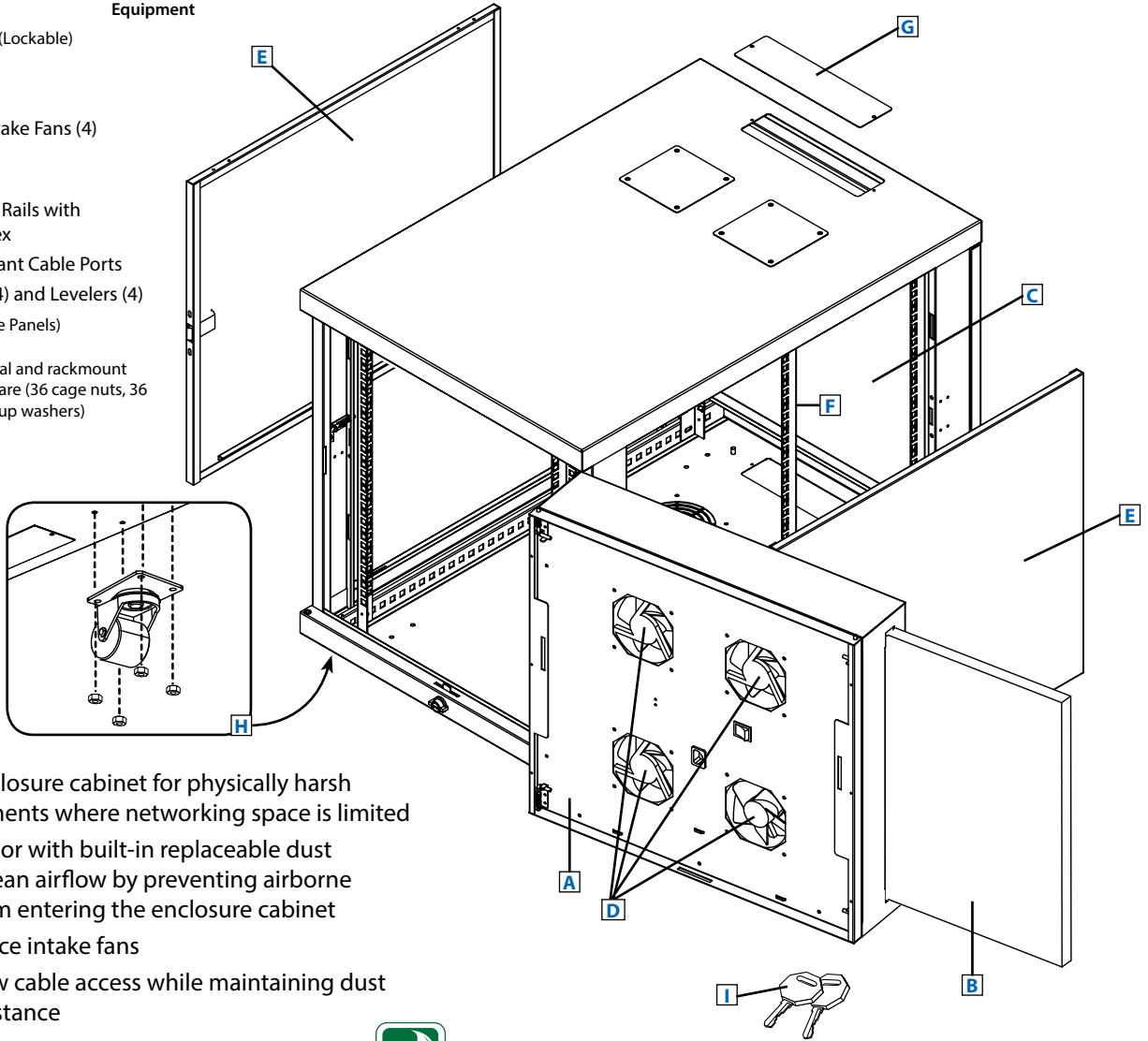

- 12U floor rack enclosure cabinet for physically harsh working environments where networking space is limited
- Louvered front door with built-in replaceable dust filter maintains clean airflow by preventing airborne contaminants from entering the enclosure cabinet
- 4 high-performance intake fans
- 2 cable ports allow cable access while maintaining dust and moisture resistance

Specifications

Model	SRX12UBFFD
Rack Spaces	12U
Equipment Mounting Depth	826 mm
Load Rating*	453 kg
Unit Dimensions (H x W x D)	640 x 600 x 978 mm
Shipping Dimensions (H x W x D)	757 x 686 x 1044 mm
Unit Weight	43.5 kg
Shipping Weight	59 kg
Standards	Meets EIA-310-E, IEC 60297-3-100, IP54, and RoHS standards

* The load rating includes the combined weight of the unit and installed equipment. The unit must be mounted to a stable surface with user-supplied anchors capable of bearing the full load.



SEE NEXT PAGE FOR DETAILED UNIT MEASUREMENTS



1111 W. 35th Street
Chicago, IL 60609 USA
773.869.1234
www.tripplite.com

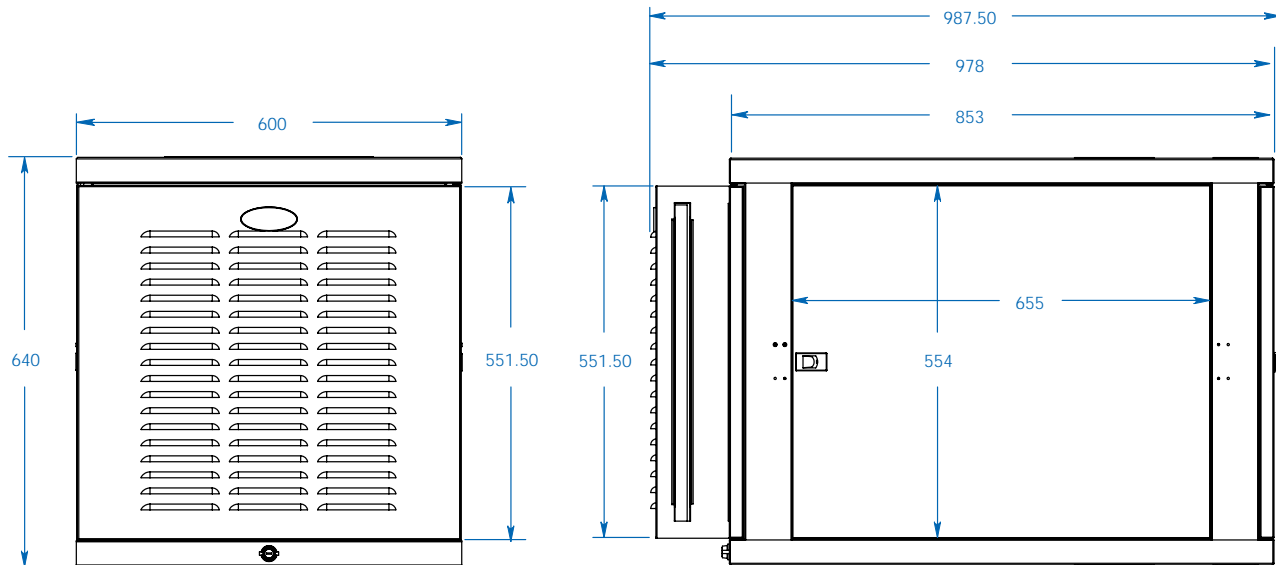

FRONT VIEW

SIDE VIEW

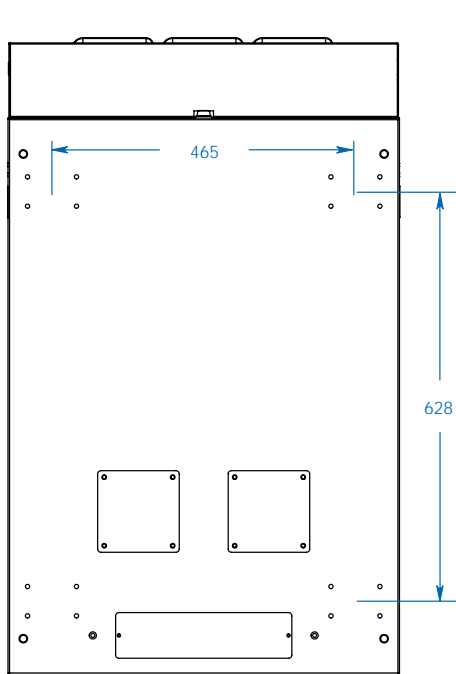

BOTTOM VIEW

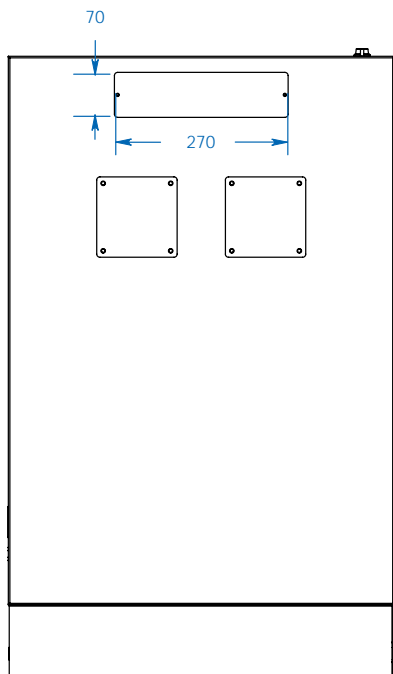

TOP VIEW

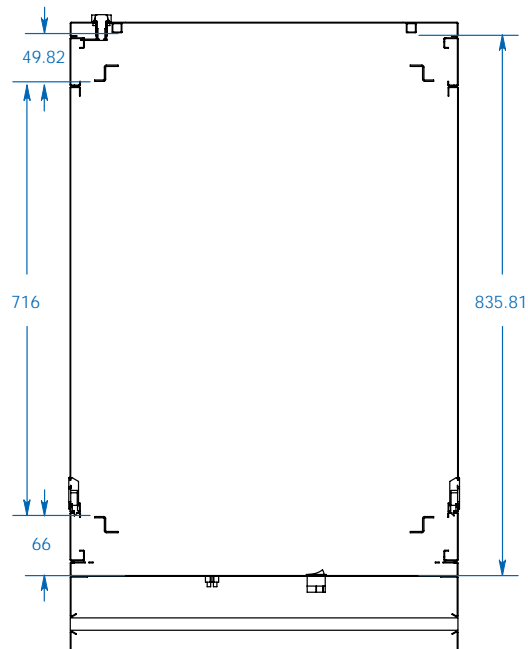

CROSS SECTION A
USABLE MOUNTING DEPTH

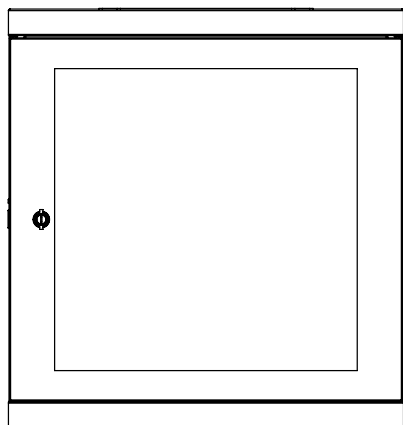

REAR VIEW

Dimensions: mm

Tripp Lite has a policy of continuous improvement. Specifications are subject to change without notice.

MODEL:
SRX12UBFFD
TRIPP·LITE

1111 W. 35th Street
Chicago, IL 60609 USA
773.869.1234
www.tripplite.com