

MODEL:

SRW21U

SmartRack® Wall-Mount Rack Enclosure Cabinet



21 Rack Units



200 lb.
Load Rating



Sturdy Steel
Construction



Locking Doors
& Side Panels



Standard
19" Rack Width



Convenient
Cable Access



Adjustable
Mounting Rails



Ventilated for
Ample Airflow



Reversible
Cabinet

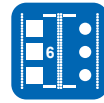

Square/Threaded
Hole Mounting

- A** Front Door
(Lockable/Removable/Reversible)
- B** Adjustable Mounting Rails (2)
(Support square and threaded hole mounting options.)
- C** Side Panels (2)
(Lockable/Removable)
- D** Mounting Plate
(Removable. Includes mounting
hooks for cabinet.)
- E** Cable Access Port Covers (2)
(Removable)
- F** Ventilation Fan Ports (4)
(Support optional SRFANWM fan kit.)
- G** Keys (2)

Also Includes: Owner's manual, mounting plate screws (3), cabinet ground screw, pre-installed front door ground wire and rack-mount equipment mounting hardware (44 cage nuts, 44 M6 x 16mm mounting screws, 44 #12-24 x 5/8" mounting screws, 44 nylon cup washers)

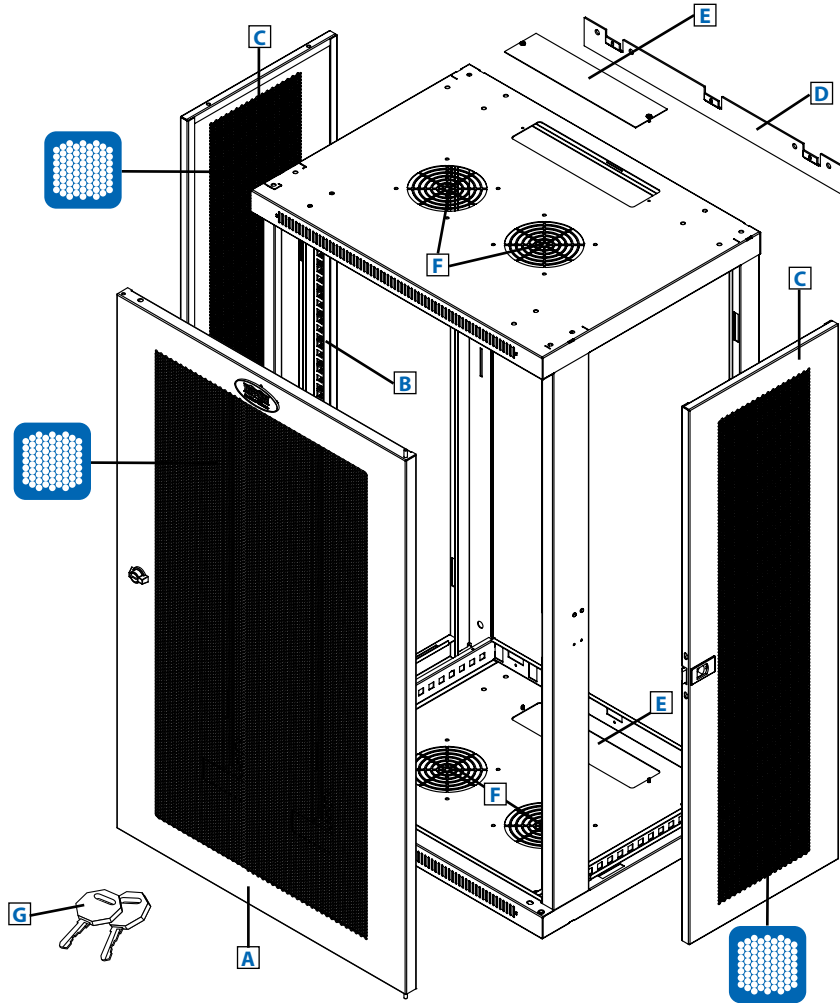
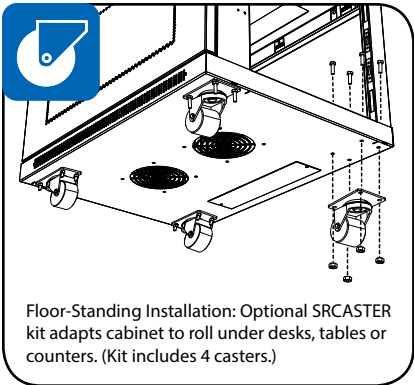

- Wall-mount enclosures provide convenient, locking storage for rack-mount IT devices and other equipment that should be off the floor, out of the way and secure
- The cabinet is fully reversible, allowing installers to change door hinges from left to right by simply rotating the unit 180 degrees before mounting

SEE NEXT PAGE FOR DETAILED UNIT MEASUREMENTS



1111 W. 35th Street
Chicago, IL 60609 USA
773.869.1234
www.tripplite.com

Specifications

Model	SRW21U
Rack Spaces	21U
Equipment Mounting Depth	Up to 16.5 in. / 419 mm
Load Rating*	200 lb. / 90.7 kg
Unit Dimensions (H x W x D)	40.87 x 23.63 x 17.72 in. / 1038 x 600 x 450 mm
Shipping Dimensions (H x W x D)	45.87 x 26.61 x 18.98 in. / 1165 x 676 x 482 mm
Unit Weight	51 lb. / 23 kg
Shipping Weight	67.8 lb. / 30.8 kg
Standards	Tested to UL/CSA 60950-1, IEC 60950-1, RoHS, NOM (Mexico), EIA/ECA-310-E, GOST

* The load rating includes the combined weight of the unit and installed equipment. The unit must be mounted to a stable surface with user-supplied anchors capable of bearing the full load.



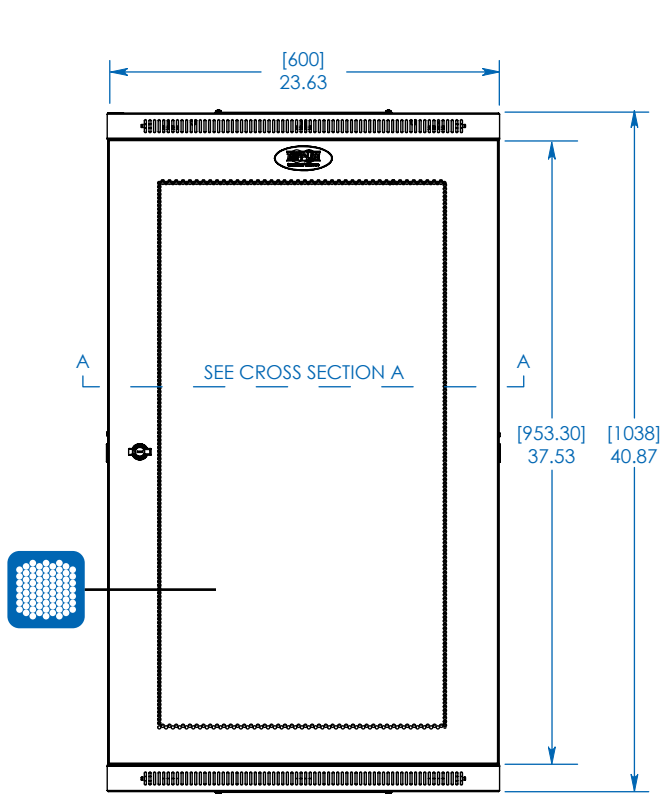

FRONT VIEW

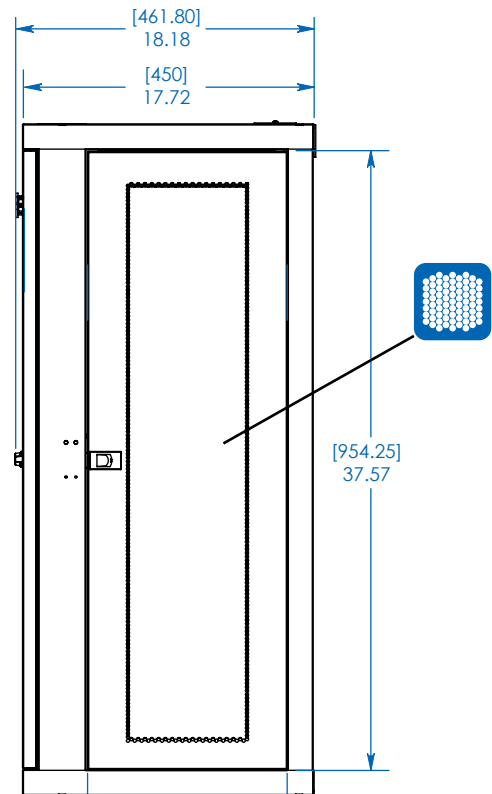

SIDE VIEW

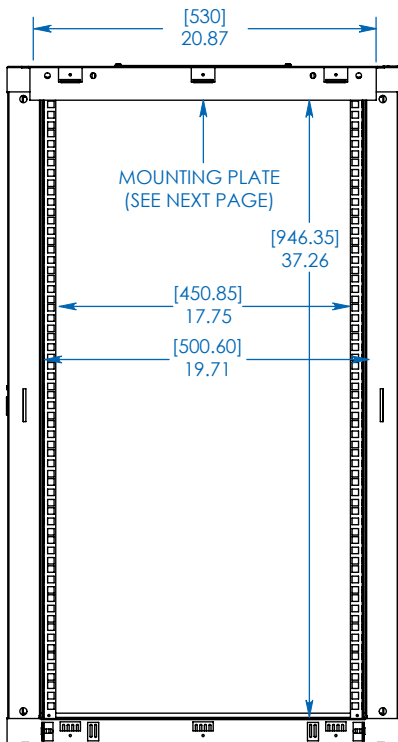

REAR VIEW (FRONT DOOR NOT SHOWN)

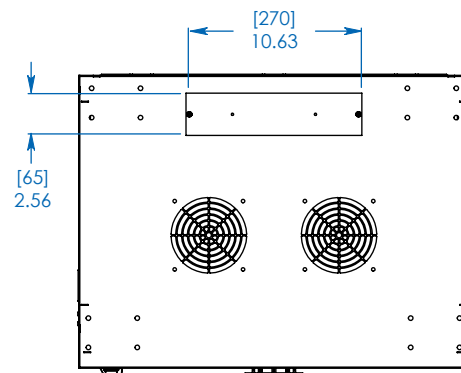

TOP/BOTTOM VIEW

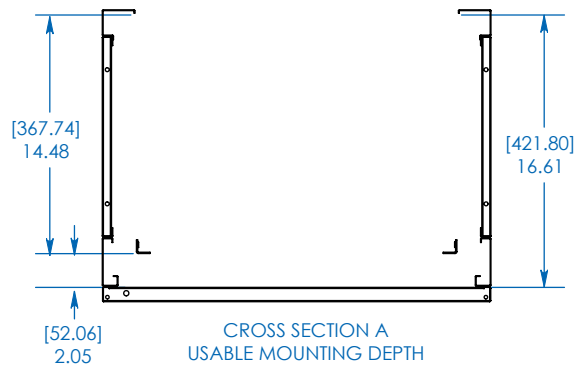

CROSS SECTION A
USABLE MOUNTING DEPTH

MODEL:

SRW21U



Dimensions: [mm] INCHES

Tripp Lite has a policy of continuous improvement. Specifications are subject to change without notice.

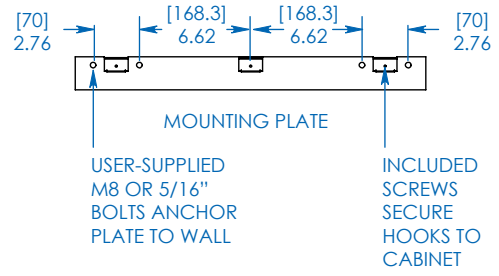
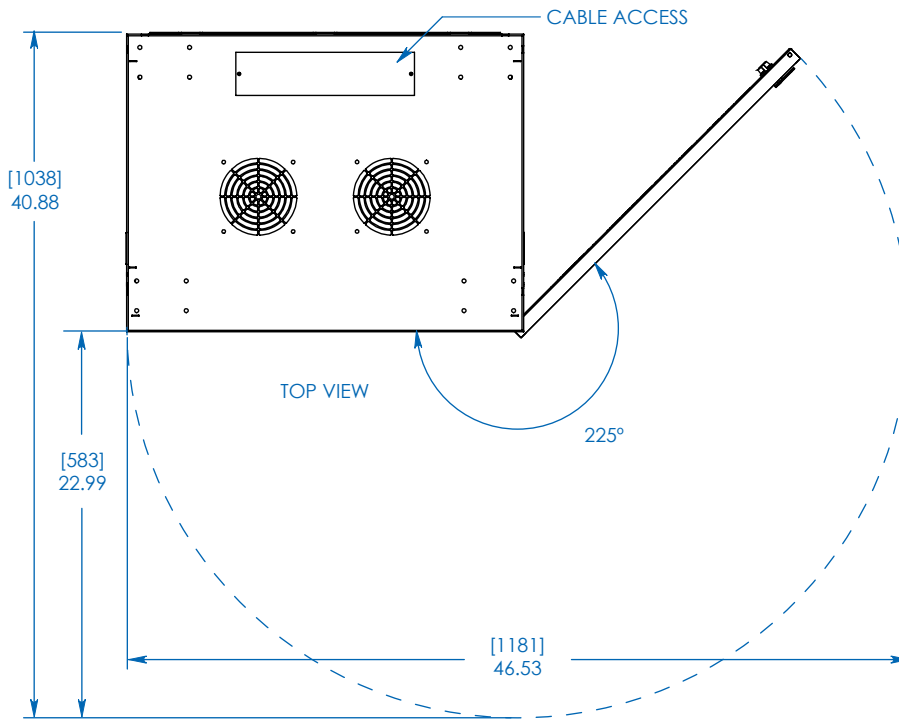

MODEL:
SRW21U

TRIPP·LITE

1111 W. 35th Street
Chicago, IL 60609 USA
773.869.1234
www.tripplite.com

Dimensions: [mm] INCHES

Tripp Lite has a policy of continuous improvement. Specifications are subject to change without notice.